

**MAXIMUS**

Completion Systems



**LINER HANGER SYSTEMS**

365 Manjusar G.I.D.C.,  
Taluka Savli,  
Vadodara- 391745,  
Gujarat State,  
India.

[www.maximuscompletions.com](http://www.maximuscompletions.com)

**MAGNUS RETRIEVABLE  
PACK-OFF BUSHING**

|               |            |
|---------------|------------|
| TECH UNIT No. | 268        |
| MODEL         | MRPOB      |
| DATE          | 08/01/2018 |
| REV.          | 00         |

**DESCRIPTION & APPLICATION:**

It provides a superior liner to work string seal that retrieves with removal of the liner running/setting tools and eliminates any bushing drill-out.

It is pressure-balanced assembly that does not exert any damaging loads onto the polished cementing seal joint. All seals are provided in material. Locking-dog assemblies are spring-loaded to insure positive engagement, particularly in high-angle or horizontal applications. It is easily installed in the field and requires no special handling or assembly tools.

It is of heavy-duty design and construction, ensuring a long, usable service life. Standard configurations allow for slip on installation over a retrievable cementing seal joint. It may be run in conjunction with any running tool sub, liner top packer, or tieback seal nipple packer equipped with its profile.

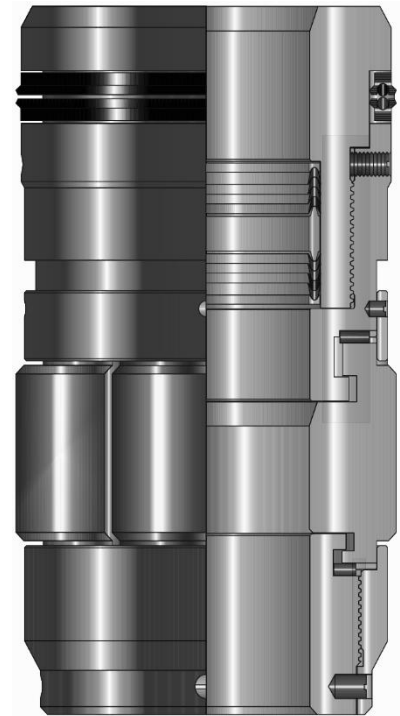
**FEATURES/ BENEFITS:-**

- Positive locking dogs
- HNBR internal & external seals
- Pressure loading on support sleeve not cementing seal joint.
- Easy field installation