

MAXIMUS

Completion Systems



LINER HANGER SYSTEMS

365 Manjusar G.I.D.C.,
Taluka Savli,
Vadodara- 391745,
Gujarat State,
India.

www.maximuscompletions.com

**MAGNUS DEBRIS JUNK SCREEN
(MDJS)**

TECH UNIT No.	264
MODEL	MDJS
DATE	06/01/2018
REV.	00

LINER HANGER SYSTEMS TECHNICAL UNIT

Authored by: RAJAT

MAGNUS DEBRIS JUNK SCREEN

Approved by: Jogendra Singh

DESCRIPTION & APPLICATION:

The Model "MDJS" Magnus Debris Junk Screen should be run as part of the setting tool assembly to prevent debris from damaging the polished bore Tieback Receptacle. It will also prevent debris from setting on top of the setting tool and ease of retrieval.

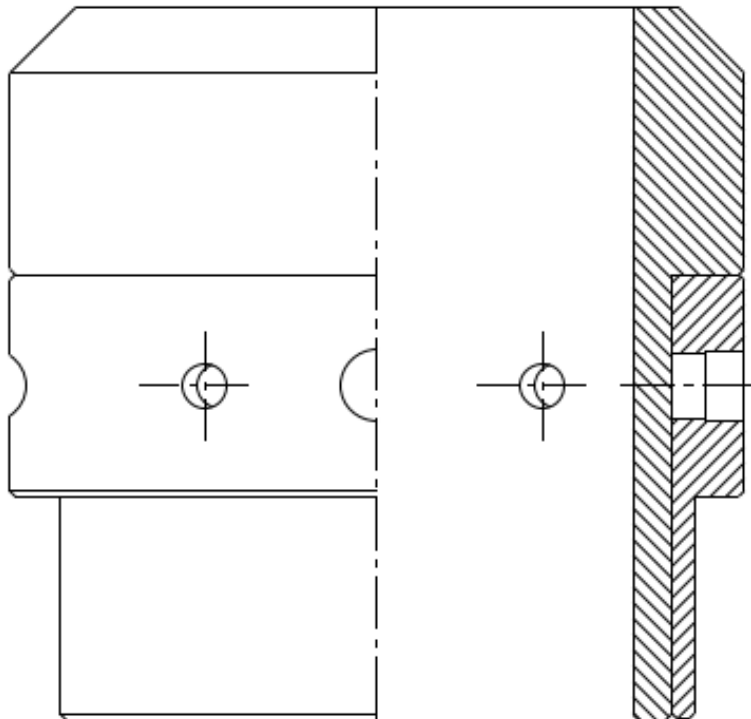

SIZE AVAILABILITY :

- AVAILABLE SIZES :- 3-1/2" TO 20".