

**MAXIMUS**

Completion Systems



**LINER HANGER SYSTEMS**

365 Manjusar G.I.D.C.,  
Taluka Savli,  
Vadodara- 391745,  
Gujarat State,  
India.

[www.maximuscompletions.com](http://www.maximuscompletions.com)

**MAGNUS CASING CEMENTING HEAD**

**LINER HANGER SYSTEMS  
TECHNICAL UNIT**

Authored by: RAJAT

TECH UNIT No.	282
MODEL	MCCH
DATE	06/01/2018
REV.	00

**MAGNUS CASING CEMENTING HEAD**

Approved by: Jogendra Singh

**DESCRIPTION :**

The cementing Head is used for cementing the annular space between casing and bore hole during 2nd stage of well construction cycle. The cementing head is employed to connect the pumps of the cementing trucks to the casing string and provides access for insertion of the cementing plugs.

Magnus Cementing heads are available in sizes 4 1/2 " to 20", for working pressure of 2,000 to 10,000 psi. Cementing head sizes & working pressures are inversely related. Generally, for smaller sizes are high working pressure and for larger sizes less working pressure are the requirements. Cementing heads could be of single plug or double plug types. Caps are "Acme" threaded or quick lock type and fitted with swivel chain assembly. The double plug cementing head has three valve manifold and two plunger assembly. Cementing heads are manufactured from solid forged rounds of alloy steels AISI 4130/4140/4145 or equivalent material and are fully heat treated.

**CEMENTING OPERATIONS:**

Magnus Cementing Head is suitable to carry out single stage as well as double stage cementing operation. It is provided with the following features:

- Simple in operation and provides easy loading of plugs.
- Having manifold with lo-torque plug valve.
- Provides continuous operation.
- The plug container holds one or two plugs, the top plug and the bottom plug. The double plug container has a three in-torque valve manifold and two plunger assembly.
- The length of plug containers are made to accommodate the standard length of plugs.
- The cap is available with ACME thread and with lifting chain for lifting the plug container.
- Adapters are available with all casing threads and butress threads.
- The standard adapters have a 6-inch-Long space with thread protectors.

TECH UNIT No.	282
MODEL	MCCH
DATE	06/01/2018
REV.	00

**CEMENTING MANIFOLDS :**

Cementing manifolds are supplied with cementing heads or alone as per customer preference. It is an assembly of unions, plug valves, tee, nipples etc. These can be supplied in any size up to pressure ratings of 10,000 psi pressure.

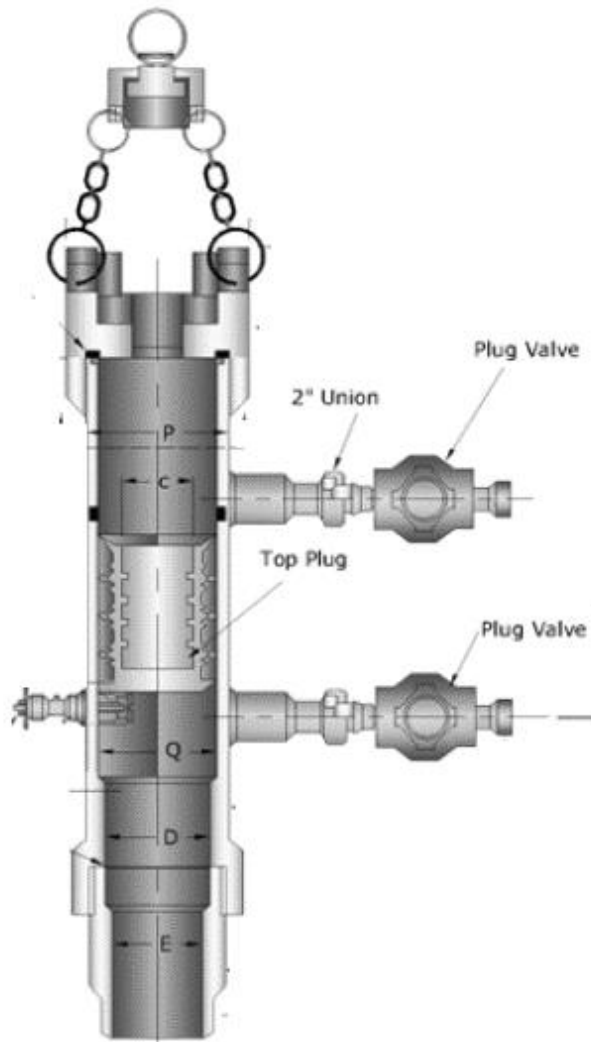

**CASING CEMENTING HEAD (SINGLE PLUG)**

**LINER HANGER SYSTEMS  
TECHNICAL UNIT**

Authored by: RAJAT

TECH UNIT No.	282
MODEL	MCCH
DATE	06/01/2018
REV.	00

**MAGNUS CASING CEMENTING HEAD**

Approved by: Jogendra Singh

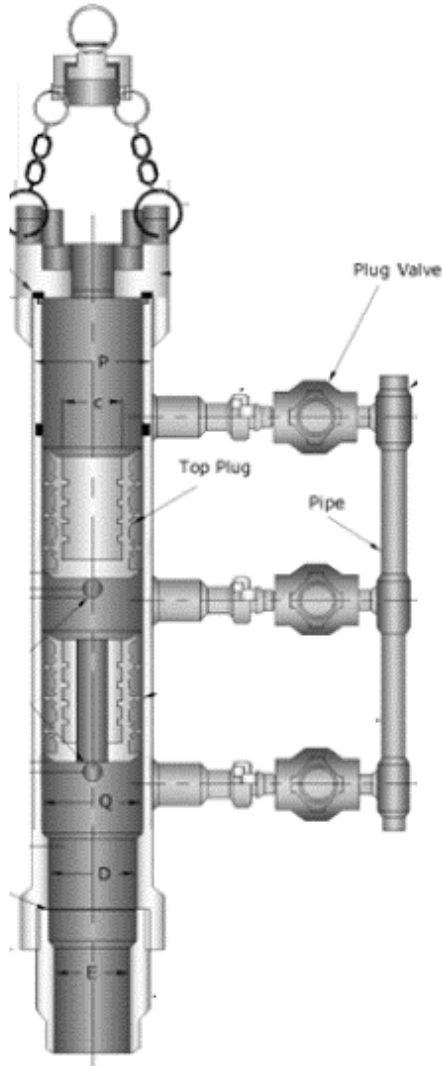

**NON-QUICK LATCH TYPE  
(WITH DOUBLE PLUG)**

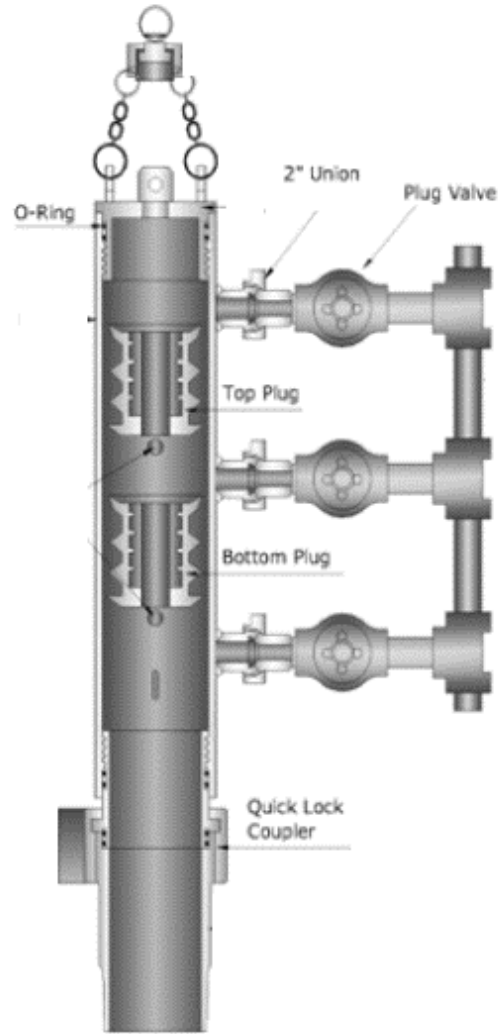

**QUICK LATCH TYPE  
(WITH DOUBLE PLUG)**