

MAXIMUS

Completion Systems



FLOAT EQUIPMENTS

365 Manjusar G.I.D.C.,
Taluka Savli,
Vadodara- 391745,
Gujarat State,
India.

www.maximuscompletions.com

**MAGNUS STAB IN CEMENT FLOAT
SHOE/COLLAR**

TECH UNIT No.	309
MODEL	MSICFS/MSICFC
DATE	06/01/2018
REV.	00

FLOAT EQUIPMENTS TECHNICAL UNIT

Authored by: Rajat

MAGNUS STAB IN CEMENT FLOAT SHOE/COLLAR

Approved by: Jogendra Singh

DESCRIPTION & FEATURES :

- ◆ Utilized for most inner string cementing applications.
- ◆ Recommended where reciprocation of the casing is not required during circulation.
- ◆ Recommended for use with Latch Down Drill Pipe Wiper Plug.
- ◆ IF stab in stinger required.
- ◆ PDC drillable

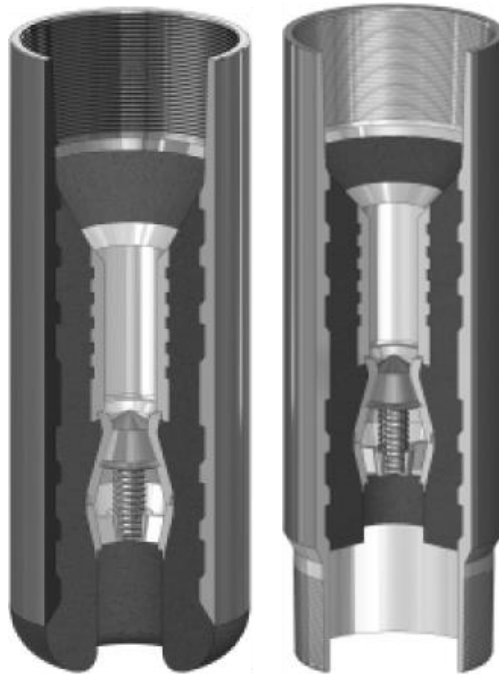

SIZE AVAILABILITY:

- ◆ 3-1/2" TO 30.00".